

ALTRA LIFT

HAND PALLET TRUCK

The Altra Lift hand pallet truck is a budget-conscious product ideal for use on-the-go. The Altra Lift has adjustable push rods that provide reliable performance and quick, easy maintenance. It is designed with self-lubricating bushings at all pivot points that help improve efficiency and minimize wear.

This product is designed for light-duty use on loading docks, delivery trucks, or moving product from backroom storage to retail shelving. Available in multiple fork configurations — you can count on Raymond to deliver a hand truck fit for your use.

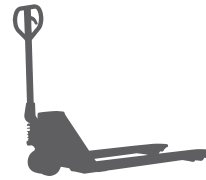

STANDARD SPECIFICATIONS:

- Capacity: 4,000, 5,500, or 6,000 lbs
- Fork OAW: 20.5", 27"
- Fork width: 6.25"
- Fork length: 36", 42", 48", 72"
- Fork height (lowered): 3"

Options*

- Load and steer wheel material
- 48" Load backrest
- Additional colors available

**Not all options available on all configurations.
Contact hptorders@raymondcorp.com*

FOR ORDERS OR INQUIRIES CALL 1.800.558.6012 OR EMAIL HPTORDERS@RAYMONDCORP.COM

If you're looking for a partner with the tools and experience to help you run better and manage smarter, contact us today at 1-800-235-7200 or visit us at raymondcorp.com.

RAYMOND

ALTRA HAND PALLET TRUCK

PRODUCTIVITY

The forks have solid nylon fork tip entry rollers that ease the transition over the bottom pallet boards, helping you to get more work done.

DURABILITY

The adjustable push rods and self-lubricating bushings at all pivot points help improve warehouse efficiency and minimize wear and tear.

ERGONOMICS

The handle with the 3-way position lever provides comfortable and precise load control for the operator. The handle return spring automatically restores the handle to its vertical position.

FLEXIBILITY

Every operation runs differently. That's why the Altra Lift is designed to adapt to a wide range of operations and is available in a variety of configurations.



Polyurethane on steel core load and steer wheels.



Teardrop handle with 3-way position lever for load control.



Hydraulic pump with over-load bypass valve.

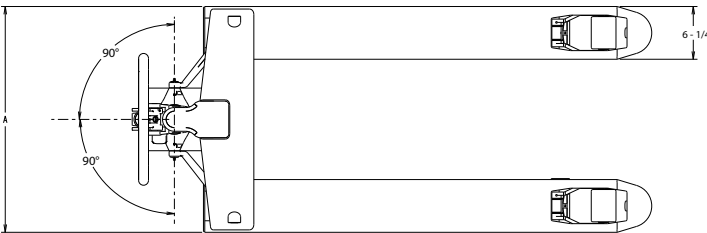

***Overall Width (A):**
20.5", 27"

***Fork Lengths (B):**
36", 42", 48", 72"

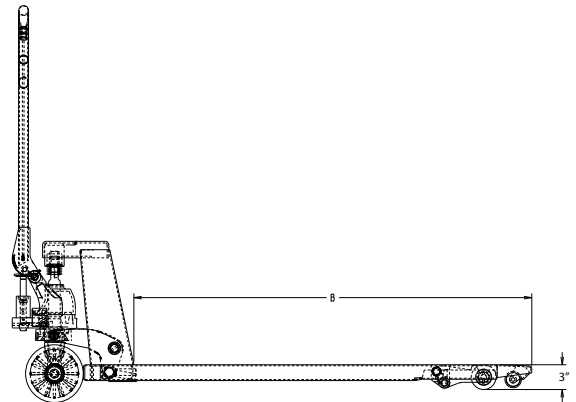

***Available Capacity:**
4,000, 5,500, 6,000 lbs.

**Fork Lengths and widths are capacity dependent. For available configurations contact hptorders@raymondcorp.com*