

RJ50N

HAND PALLET TRUCK

The Raymond RJ50N is the logical choice for everyday use throughout your operation. These reliable hand pallet trucks are often used on delivery trucks, on docks, or anywhere a performance truck is needed. The RJ50N features the smooth handling and exceptional maneuverability that are hallmarks of all Raymond hand pallets trucks. Our trucks are designed for easy maintenance with multiple configurations and a wide range of product features and options to meet your performance needs.



STANDARD SPECIFICATIONS:

- Capacity: 5,500 lbs
- Fork OAW: 16", 20.5", 27"
- Fork width: 6.25"
- Fork length: 36", 42", 48"
- Fork height (lowered): 3"

Options*

- Load and steer wheel material
- Brake
- Quick-lift pump
- 48" or 60" load backrest

**Not all options available on all configurations.
Contact hptorders@raymondcorp.com*

FOR ORDERS OR INQUIRIES CALL 1.800.558.6012 OR EMAIL HPTORDERS@RAYMONDCORP.COM

If you're looking for a partner with the tools and experience to help you run better and manage smarter, contact us today at 1-800-235-7200 or visit us at raymondcorp.com.

RAYMOND

RJ50N STANDARD SERIES

PRODUCTIVITY

The Raymond Model RJ50N has full 180-degree turning radius providing exceptional maneuverability in tight areas. Standard variable speed lowering reduces the chance of product damage. Entry and exit rollers provide smooth transitions in and out of pallets, and improved load handling.

DURABILITY

10 grease points throughout the chassis and a one-piece, sealed cast iron hydraulic pump allow Raymond pallet trucks to withstand the most demanding applications year after year.

ERGONOMICS

Fingertip controls provide convenient access to lift, lower and neutral positions. The handle return spring automatically restores the handle to its vertical position.

FLEXIBILITY

Raymond knows that every operation runs differently. That's why the RJ50N is designed to adapt to the demands of a wide range of warehouse operations.



Fingertip controls provide convenient access to lift, lower and neutral.



Simplified pump assemblies use fewer parts and feature uniquely packed seals.



Bushings feature easily accessible grease fittings.



***Overall Width (A):**
16", 20.5", 27"

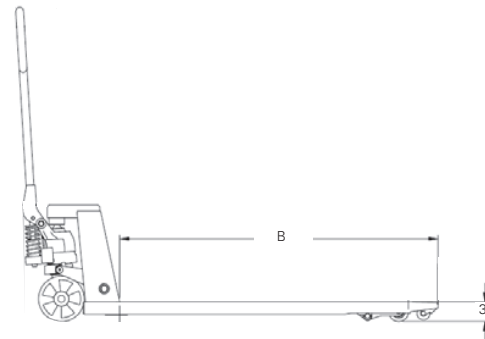

***Overall Lengths (B):**
36", 42", 48"

**Not all widths are available in all fork lengths. For available configurations contact hptorders@raymondcorp.com*